

L SYSTEM

COMPONENTS AND SOLUTIONS

INDEX

Hi!	
L-SYSTEM	4
SHAC	6
SMC	7
Linear technology	8
Profile systems	8
Pneumatics	9
Linear units	9
Gears	10
Servo systems	10
Hydraulics	11
Feeders	11
Ball bearings	12
Delivered solutions	13

L-SYSTEM AB

Mörsaregatan 20
254 66 Helsingborg
SWEDEN
info@l-system.se
+46 (0)42 38 61 50

L-SYSTEM ApS

Roms Hule 8 (Østtårne)
7100 Vejle
DENMARK
info@l-system.dk
+45 32 26 80 81

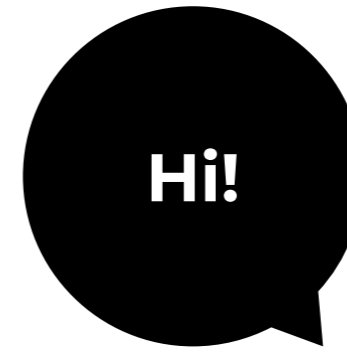

L-SYSTEM has solid experience in selling mechanics and automation components to the Nordic and European markets, something we've done since 1974.

We market and are resellers of several reputable quality brands such as Bosch Rexroth, Shac, SMC, Parker Hannifin, Schaeffler and Emerson. Other brands we lean towards are Hiwin, NSK, Legris, Transair, Afag, DECA, Fiam and ISB. The product range also includes our profile system S2, belt conveyors, linear tables and hospital trolleys.

On stock we always have a wide range of aluminum profiles and accessories, rail guides, ball screws and nuts, steel shafts and pneumatic components. A shortage is quickly addressed via our many purchasing channels to quickly meet needs and wishes.

In addition to this, we also carry out assembly and machining of profile systems, ball screws, pneumatic cabinets and the machine park includes the possibilities for both milling and turning.

The idea is to market quality products and finding solutions at reasonable prices, while at the same time supporting our customers with fast service and high technical know-how - the ambition, a complete partner where flexibility is key. And of course a thorn in the side of our competitors.

At the head office in Helsingborg and at the sales office in Vejle, Denmark, we are a small group of dedicated and diverse employees who push each other to improve all aspects of what we deliver.

We are a small big company, quite simply.

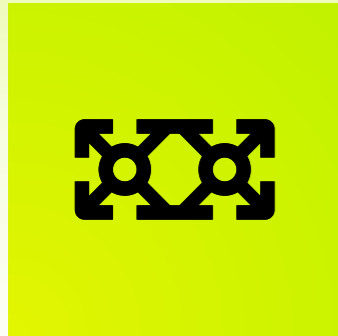

L-SYSTEM

What application is required?
We'll guide you.

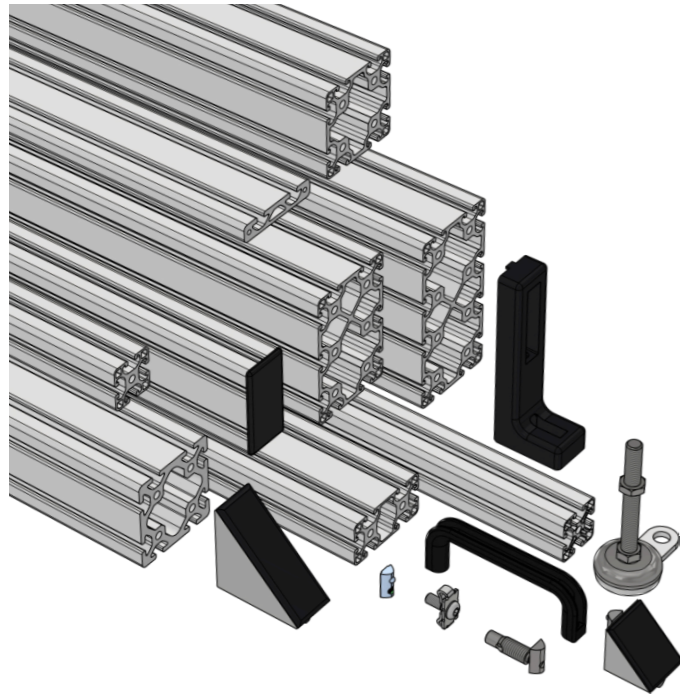

Profile system S2

- Fits all i-profile* systems
- Ideal for constructing stands, enclosures, trolleys and workstations
- Large stock of profiles and fittings
- Delivered as lengths, mounting kit or completely assembled
- L-SYSTEM does the engineering, cutting and machining

**Fully compatible with the Item profile system.*

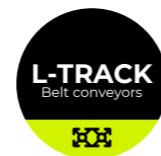

Belt conveyor L-TRACK

- Great option for moving products
- Based on our profile system S2 (T-slot 8) or optionally with Bosch profile (T-slot 10)
- Wide range of belts for different purposes and environments
- Available with a stand, both fixed and adjustable
- Possible to get with drum motor*
- L-SYSTEM does the engineering, cutting, machining and assembly

**Not suitable for all applications.*

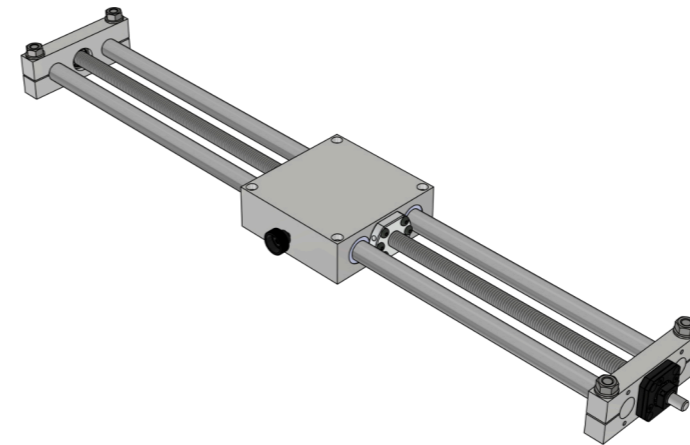

Linear tables LS-LT

- For adjustment applications in vertical or horizontal direction
- Available with manual or electric drive
- Different sizes available
- More economical alternative to linear modules
- L-SYSTEM does the engineering, cutting, machining and assembly



Hospital trollys LS-HT

- Ideal for hospital and clean room environments
- Based on our profile system S2 (T-slot 6)
- L-SYSTEM does the engineering, cutting, machining and assembly



Taiwan-based SHAC was founded early in the early 2000s and for the first ten years focused on linear transmission manufacturing.

Today the company has evolved into a modern enterprise with R&D, a large production, sales and trade departments.

With the quality concept of "Quality is the mission given by the market", the company always tightens the "quality nerve".

In order to control the quality of the products, SHAC have introduced and independently developed a number of testing equipment: the slider finished product testing line, the screw lead tester, the Rockwell hardness tester, the profiler, the projector, and the metallographic microscope. SHAC has put customer satisfaction into the daily work.



SHAC

- Taiwan based - high end brand
- L-SYSTEM is general agent for the markets in Scandinavia
- The range includes ball rails, blocks, ball screws, support units, bushings and shafts
- The products are on par and equivalent to Hiwin
- Wide range of sizes, pre-loads and accuracy classes
- DIN Standard 69051
- Scandinavia's largest stock
- L-SYSTEM does the engineering, cutting and machining



SMC Corporation was founded in April 1959 in Tokyo, Japan, and today has over 21,600 talented employees in over 80 countries worldwide.

Since SMC entered the pneumatics market, we have evolved, along with our customers' requirements, to build a comprehensive portfolio of automated control equipment. 12,000 basic products and over 700,000 variants, designed to give you greater competitiveness.

Customer satisfaction is at the heart of our mission; constant communication with our market is the mechanism.



SMC

- Japan based - high end brand
- L-SYSTEM is a system partner in Sweden and Denmark
- The range includes, among other things, actuators, valves, airlines, fittings and tubing
- Wide range of sizes and accuracy classes on stock
- ISO 15552
- L-SYSTEM offers the option of fully assembled pneumatic cabinets

Linear technology



Linear technology

- High-end and mid-segment products
- Rails, blocks (ball- and roller rails), ball screws and nut, shafts, bushings and ball bearings
- Wide range of sizes, pre-loads and accuracy classes
- Scandinavia's largest stock of rails and blocks
- L-SYSTEM does the engineering, cutting and machining



**In Sweden, only complete systems are sold and distributed.
In Denmark, both systems and components are available.*



Pneumatics



Pneumatics

- High-end and mid-segment products
- Complete systems
- Wide range on stock
- L-SYSTEM offers the option of fully assembled pneumatic cabinets



Profile systems

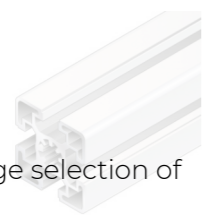

Profile systems

- Complete systems with a large selection of profiles and accessories
- Belt, pallet and chain conveyors
- Delivered as lengths, mounting kit or completely assembled
- Scandinavia's largest stock of profiles and fittings
- L-SYSTEM does the engineering, cutting, machining and assembly



Linear units

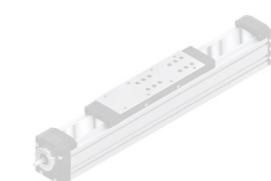

Linear units

- High-end segment
- Service and repair
- Custom flange to other motor/gear manufacturers possible
- L-SYSTEM does the engineering (and flange customization)



Gears



Gears

- High-end segment
- Large selection from basic to premium
- Complete solution with gearbox, motor, pinion and rack possible
- L-SYSTEM does the engineering



Hydraulics



Hydraulics

- Complete system
- High load capacities
- Adapted for Bosch Rexroth linear units
- Good absorption/cushioning

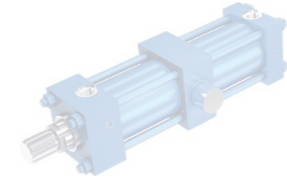

Servo systems



Servo systems

- Complete system
- Open interface
- Adapted for Bosch Rexroth linear units
- L-SYSTEM does the engineering

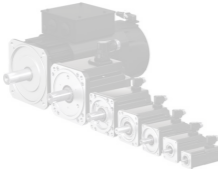

Tighteners



Tighteners

- Air or electric tighteners
- Drills, tappers, grinders and sanders
- Manual or automatic solutions



Feeders



Feeders

- Complete system
- Control devices
- Linear, rotary and gripper modules



Ball bearings



Ball bearings

- High-end and mid-segment products
- Wide range of sizes and accuracy classes



Delivered solutions

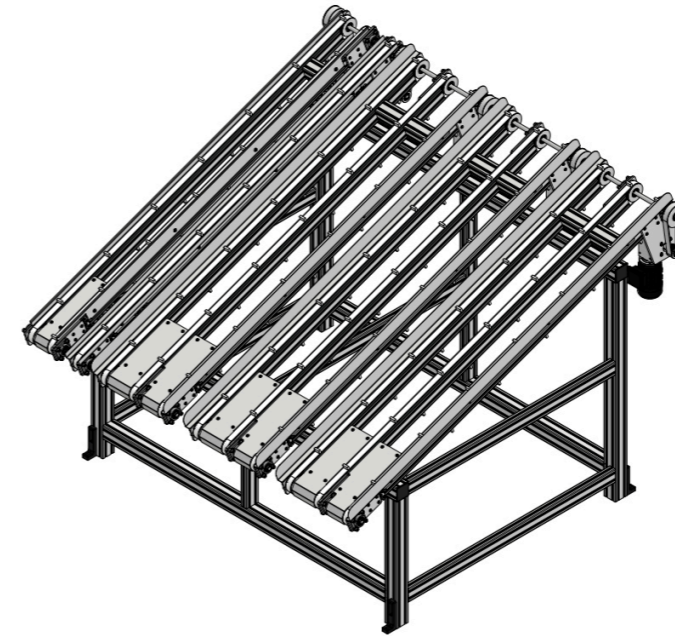

Timing belt driven L-TRACK

Timber industry
Handling of machined details
Custom made

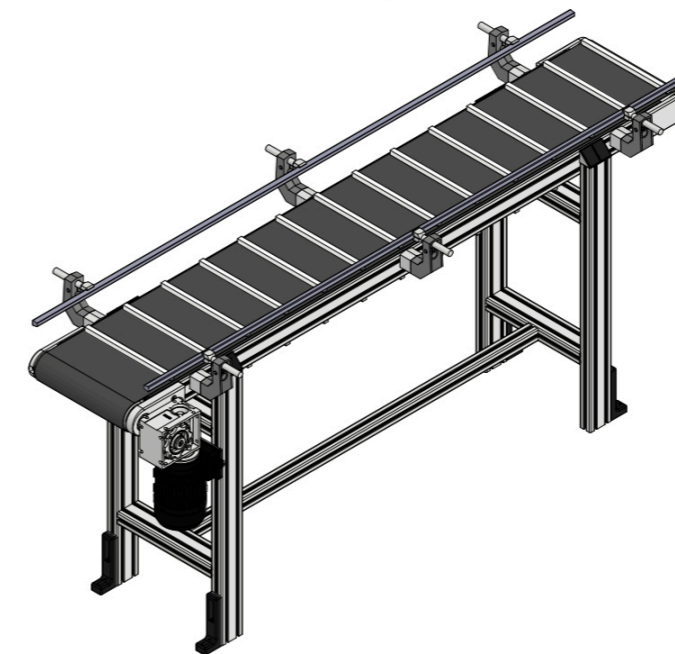

Belt driven L-TRACK

Manufacturing industry
Handling of finished products
Custom made

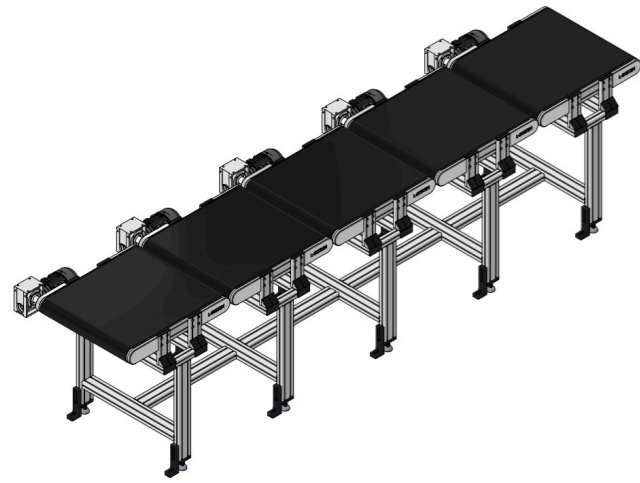

Belt driven L-TRACK

Manufacturing industry
Handling of machined details
Custom made

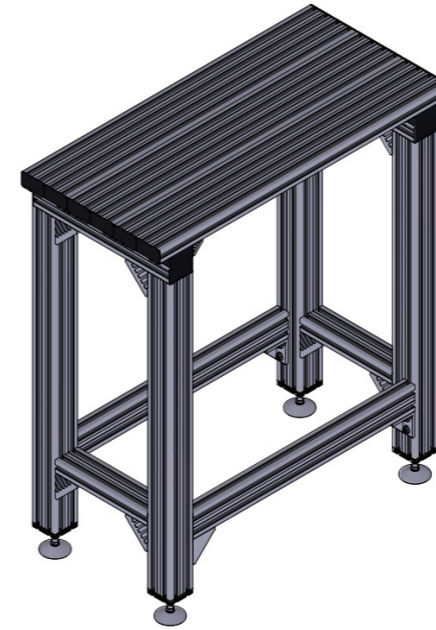
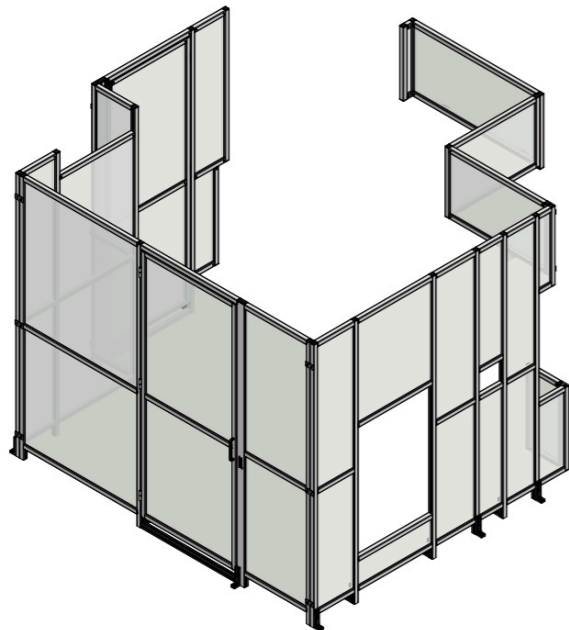

Table heavy duty (Bosch profile system)

Workshop
Table for tools and measuring instruments
Custom made



Enclosure (Profile system S2)

Pharmaceutical industry
Clean room enclosure

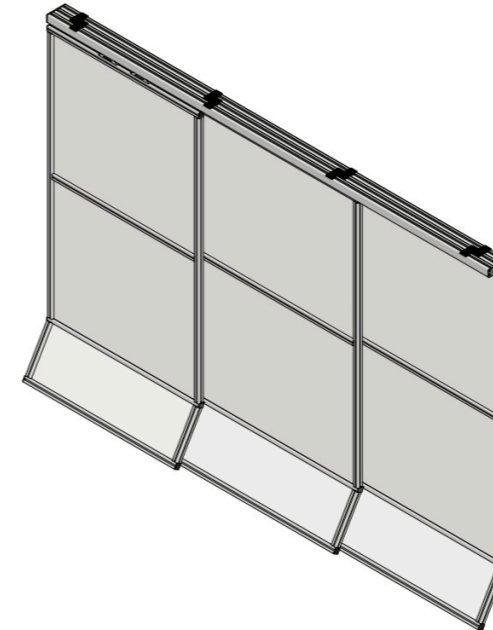

Sliding doors (Profile system S2)

Workshop
Section divider

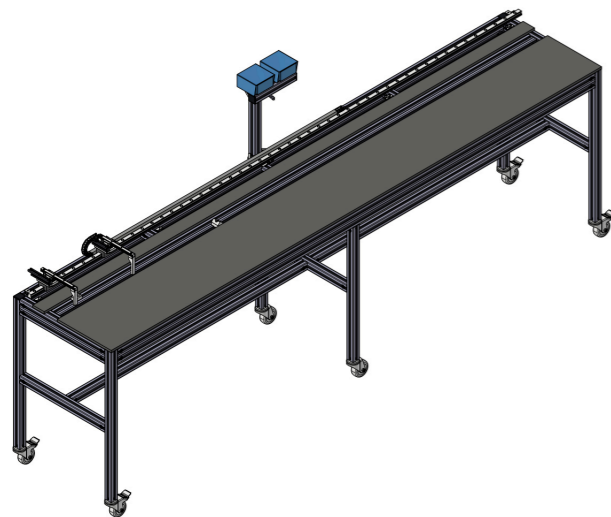

Measuring table

Manufacturing industry
Control measurement of finished products
Custom made

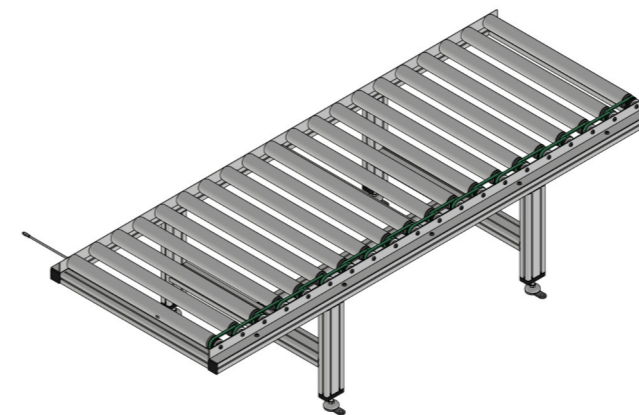

Roller driven L-TRACK conveyor

Distribution operator
Package handling
Custom made

Notes

Notes

We deliver components and solutions.

L-SYSTEM AB

Mörsaregatan 20
254 66 Helsingborg
SWEDEN
info@l-system.se
+46 (0)42 38 61 50

L-SYSTEM ApS

Roms Hule 8 (Østtårne)
7100 Vejle
DENMARK
info@l-system.dk
+45 32 26 80 81



www.l-system.se/dk/no/fi

©L-SYSTEM AB 2023 (l-system_presentation_ver_1.0b.pdf).
All other trademarks are the property of their respective
owners and are used with their permission.